

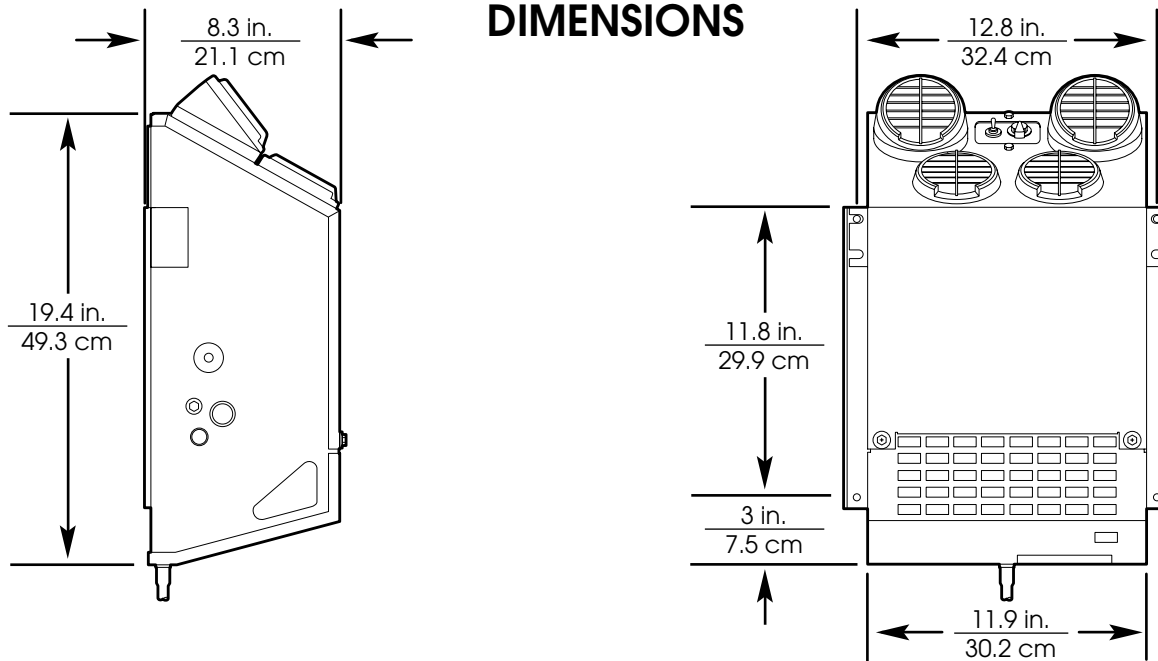

R-134a Compatible

# Red Dot Air Conditioner R-7830 Series

## TECHNICAL SALES BULLETIN AND SERVICE PARTS LIST



## SPECIFICATIONS

<b>BTU's:</b>	17,180 BTU/Hr with 36°F (4329 kcal/h w/2.2°C) Refrigerant Temp. and 80°F (26°C) Wet Bulb Entering Air
<b>Air Flow:</b>	260 CFM (442 m <sup>3</sup> /h)
<b>Weight:</b>	25 Lbs. (11 Kg)
<b>Current Draw:</b>	18 Amps @ 13.6 V.D.C. (Includes 4 Amps for A/C Clutch) 9 Amps @ 27.2 V.D.C. (Includes 2 Amps for A/C Clutch)

## SCHEMATICS

### ELECTRICAL SCHEMATIC

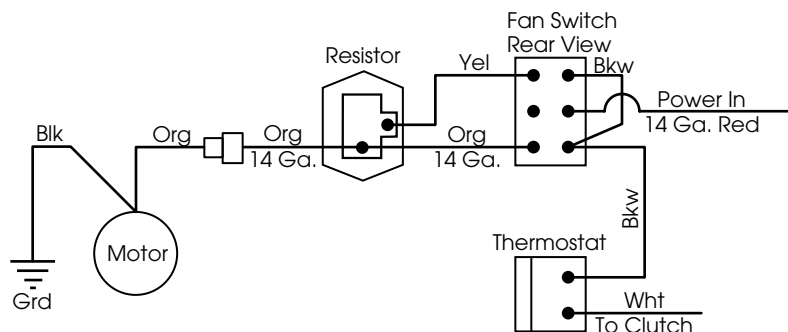

### PLUMBING SCHEMATIC

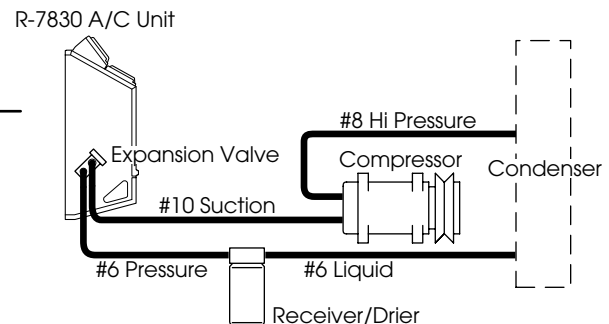

Use 30 Amp fuse or breaker (customer supplied).  
 WARNING: Unit warranty void if fused power source not used.